

MOTORESELECTRICOS.EU

MOTORES MONOFASICOS PAR MEDIO

TAMAÑO ESTÁNDAR

Carcasa de aluminio

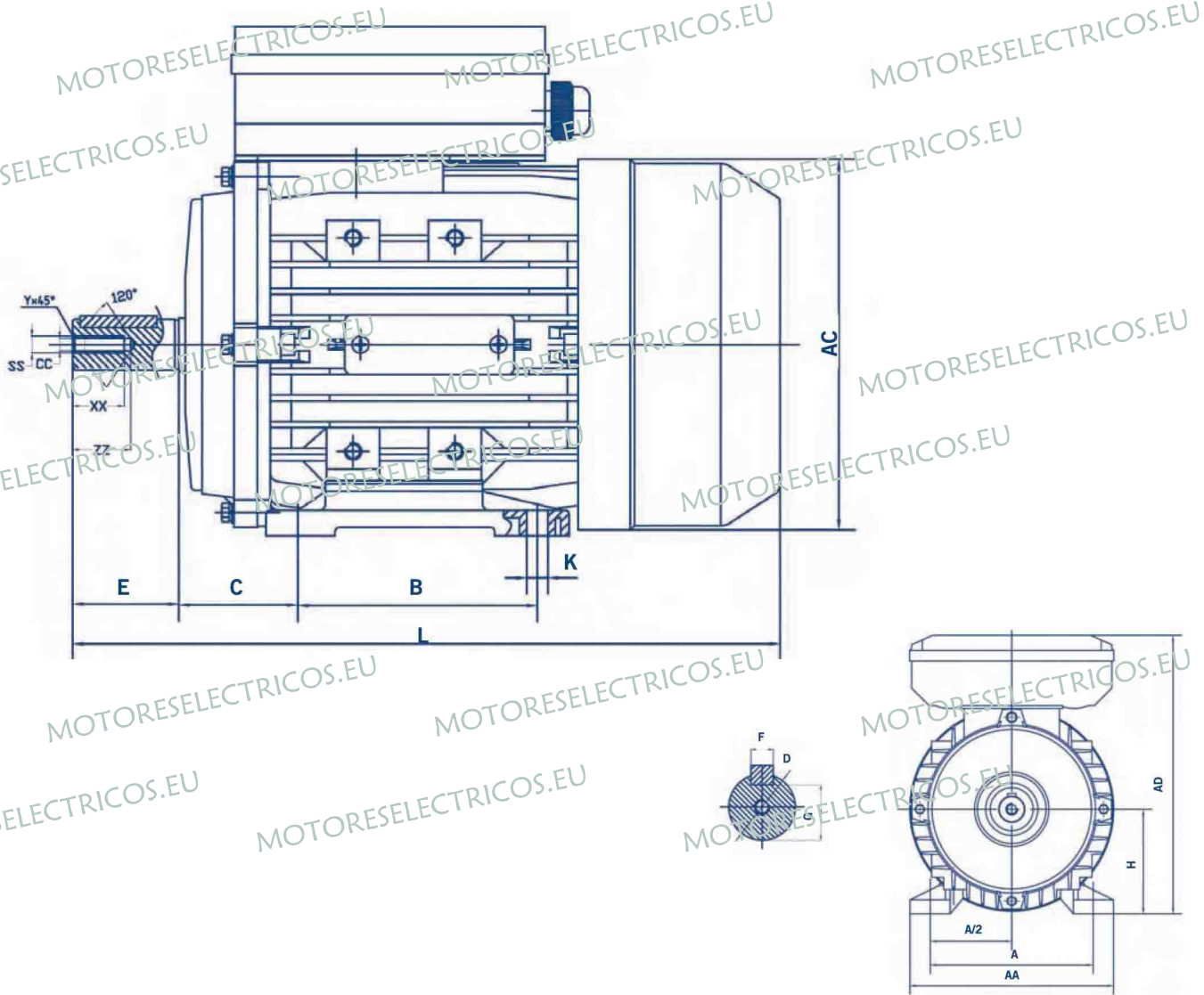

SERIE MY																															
TIPO	IMB14										IMB5																				
	A	B	C	D	E	F	G	H	K	M	N	P	R	S	T	M	N	P	R	S	T	AA	AC	AD	HD	L	SS	XX	ZZ	CC	Y
56	90	71	36	9	20	3	7.2	56	5.8x8.	65	50	80	0	M5	2.5	98	80	120	0	∅ 7	3.0	108	115	256	100	192	M3	8	12	2.5	0.5
63	100	80	40	11	23	4	8.5	63	8	75	60	90	0	M5	2.5	115	95	140	0	∅ 10	3.0	120	130	179	116	212	M4	10	15	3.3	0.8
71	112	90	45	14	30	5	11	71	7x10	85	70	105	0	M6	2.5	130	110	160	0	∅ 10	3.5	132	145	194	123	240	M5	12	18	4.2	0.8
80	125	100	50	19	40	6	15.5	80	7x10	100	80	120	0	M6	3.0	165	130	200	0	∅ 12	3.5	157	165	223	143	290	M6	16	22	5	1
90S	140	100	56	24	50	8	20	90	10x13	115	95	140	0	M8	3.0	165	130	200	0	∅ 12	3.5	172	185	240	150	310	M8	20	25	6.8	1
90L	140	125	56	24	50	8	20	90	10x13	115	95	140	0	M8	3.0	165	130	200	0	∅ 12	3.5	172	185	240	150	335	M8	20	25	6.8	1
100L	160	140	63	28	60	8	24	100	10x13	130	110	160	0	M8	3.5	215	180	250	0	∅ 15	4.0	196	205	260	160	357	M10	22	28	8.5	1.5